

Quantum Groups and Hopf Algebras

Maxwell Jiang

December 10, 2022

Abstract

In this expository article, we give a brief introduction to quantum groups (Hopf algebras) and their applications to knot theory. Written for MIT 18.704 Seminar in Algebra.

Contents

1	Introduction	2
1.1	Algebras	2
1.2	Group algebras and representations	3
1.3	Lie algebras and representations	3
2	Hopf algebras	4
2.1	Coalgebras and bialgebras	5
2.2	Hopf algebras	8
2.3	Quasitriangular and ribbon Hopf algebras	10
3	Categories and Knots	11
3.1	Monoidal categories	11
3.1.1	Rigid categories	11
3.1.2	Braided categories	12
3.1.3	Ribbon categories	13
3.2	The diagrammatic theory	14
3.3	Knot invariants	19

1 Introduction

Quantum groups belong to a class of objects known as Hopf algebras, which were born in the 1940s out of Heinz Hopf's work in algebraic topology and group cohomology. They received considerable attention in the last half-century as the theory was developed and applied in a wide range of other areas of mathematics: Lie theory, representation theory, combinatorics, algebraic geometry, quantum mechanics, and so on. In this article, we give a brief introduction to the topic, covering just enough to see an interesting application to knot theory.

We assume the reader has a basic familiarity with undergraduate algebra: linear algebra (tensor products over a field), ring theory, group representations, and Lie algebras, though the latter two are not central to the discussion. We will also assume a basic familiarity with category theory (functors, natural transformations).

The article is organized as follows. In the remainder of the introduction, we review some ideas from the representation theory of groups and Lie algebras. Historically, this was not the original motivation for the definition of a Hopf algebra, but it is the most accessible one in the context of 18.704. In Section 2, we jump into the algebraic formalisms needed to define Hopf algebras and several important subclasses: quasitriangular Hopf algebras and ribbon Hopf algebras. We will use the objects from Section 1.2 and Section 1.3 as running examples, and we will see that the category $\mathbf{f.Mod}_H$ of finite-dimensional representations of quasitriangular Hopf algebra H generalizes both sections.

In Section 3, we cast everything into a categorical framework that lends itself to an appealing diagrammatic theory. This is the most interesting and concrete section of the article and might demystify some of the formulas from Section 2. We give an application to knot theory, discussing Drinfeld's quantum double construction along the way. A small amount of knot theory is required to fully appreciate this section; for this, we point the reader to the relevant references.

1.1 Algebras

Throughout the article, we let k denote a field. All tensor products are taken over k . We begin by reviewing some definitions and notation.

Definition 1.1. A k -algebra is a unital associative ring A equipped with a ring homomorphism (the *structure map*) $k \rightarrow A$ whose image lies in the center of A . The structure map endows A with the structure of a k -vector space.

Definition 1.2. Let A be a k -algebra. An A -module (or *representation of A*) is a k -vector space V equipped with an *action* $A \times V \rightarrow V$ denoted $(a, v) \mapsto a \cdot v$, satisfying the following conditions. The action should be k -linear, i.e. $a \cdot (-): V \rightarrow V$ is a k -linear map for all $a \in A$. The action should also be associative and respect 1, i.e. $(ab) \cdot v = a \cdot (b \cdot v)$ and $1 \cdot v = v$ for all $a, b \in A$ and $v \in V$.

A morphism $f: V \rightarrow W$ of A -modules is a k -linear map respecting the action, i.e. $f(a \cdot v) = a \cdot f(v)$ for all $a \in A$ and $v \in V$.

1.2 Group algebras and representations

For a group G , a G -module is a k -vector space V equipped with an action $G \times V \rightarrow V$ that is k -linear, is associative, and respects 1. The reader should be able to produce the definition of a G -module morphism.

This is quite similar to Definition 1.2. In fact, for an appropriate choice of k -algebra A , a G -module is “the same thing” as an A -module. This is the *group algebra* $A = kG$.

Definition 1.3 (Group algebra). Let kG denote the following k -algebra: as a vector space, it is freely generated by the elements of G . The structure map $k \rightarrow G$ sends 1 to the identity 1 of G . Multiplication in kG is defined using multiplication in G , extended linearly.

It is not hard to check that every G -module is naturally a kG -module and vice versa.¹ We now consider two constructions in the category of G -modules.

Definition 1.4 (Tensor module). Given G -modules V, W , the k -vector space $V \otimes W$ carries a natural G -module structure given by

$$g \cdot (v \otimes w) := (g \cdot v) \otimes (g \cdot w).$$

Definition 1.5 (Dual module). Given a G -module V , its linear dual $V^\vee := \text{Hom}_k(V, k)$ carries a natural G -module structure given by

$$g \cdot \alpha = (v \mapsto \alpha(g^{-1} \cdot v)).$$

Note that the action of G on V^\vee makes use of group inversion. This is to ensure to that $(gh) \cdot \alpha = g \cdot (h \cdot \alpha)$.

1.3 Lie algebras and representations

Definition 1.6. A *Lie algebra* is a k -vector space \mathfrak{g} equipped with a k -bilinear *Lie bracket* $[\cdot, \cdot]: \mathfrak{g} \times \mathfrak{g} \rightarrow \mathfrak{g}$ satisfying

$$[X, [Y, Z]] + [Y, [Z, X]] + [Z, [X, Y]] = 0 \quad \text{and} \quad [X, X] = 0 \quad \text{for all } X, Y, Z \in \mathfrak{g}.$$

Definition 1.7. A \mathfrak{g} -module is a k -vector space V with an action $\mathfrak{g} \times V \rightarrow V$ satisfying the following conditions. The action should be k -linear, i.e. $X \cdot (-): V \rightarrow V$ is a k -linear map for all $X \in \mathfrak{g}$. The action should respect the Lie structures on \mathfrak{g} and $\text{End}_k(V)$, i.e.

$$[X, Y] \cdot v = X \cdot (Y \cdot v) - Y \cdot (X \cdot v). \tag{1.3.1}$$

Somewhat misleadingly, a Lie algebra \mathfrak{g} may not be an algebra in the sense of Definition 1.1, since the multiplicative structure given by $[\cdot, \cdot]$ is not necessarily associative nor does it necessarily have 1. However, it is a fact that every Lie algebra \mathfrak{g} embeds into a Lie algebra

¹Formally, there is an *equivalence of categories* between G -modules and kG -modules. More abstract nonsense: this is a *free-forgetful adjunction*.

A (i.e. there is an injective morphism of Lie algebras $\mathfrak{g} \hookrightarrow A$), where A is a k -algebra, and the Lie bracket on A is given by the commutator

$$[X, Y] := XY - YX.$$

Moreover, there exists such an $A = U(\mathfrak{g})$ that is *universal*.² Here is an explicit construction. Choose a basis $\{g_i\}_{i \in \Lambda}$ of \mathfrak{g} , and let $k\{g_i\}$ denote the free k -algebra with generators g_i . Let I denote the two-sided ideal generated by the elements $g_i g_j - g_j g_i - [g_i, g_j]$, and define

$$U(\mathfrak{g}) := k\{g_i\}/I.$$

Then \mathfrak{g} embeds into $U(\mathfrak{g})$ in the obvious way, and $U(\mathfrak{g})$ is a k -algebra whose Lie structure (commutator) is compatible with the Lie structure of the embedded \mathfrak{g} , essentially by construction. As with all universal objects, $U(\mathfrak{g})$ is unique up to unique isomorphism, and it is termed the *universal enveloping algebra of \mathfrak{g}* . One can show that $U(\mathfrak{g})$ is to \mathfrak{g} what kG is to G : that is, a \mathfrak{g} -module is “the same thing” as a $U(\mathfrak{g})$ -module.

To further the analogy, we now consider \mathfrak{g} -module analogs of Definitions 1.4 and 1.5.

Definition 1.8 (Tensor module). Given \mathfrak{g} -modules V, W , the k -vector space $V \otimes W$ carries a natural \mathfrak{g} -module structure given by

$$X \cdot (v \otimes w) := (X \cdot v) \otimes w + v \otimes (X \cdot w).$$

Diligent readers may wish to check for themselves that Equation 1.3.1 holds for $V \otimes W$.

Definition 1.9 (Dual module). Given a \mathfrak{g} -module V , its dual V^\vee carries a natural \mathfrak{g} -module structure via

$$X \cdot \alpha := (v \mapsto \alpha(-X \cdot v)).$$

Observe that the minus sign ensures that $[X, Y] \cdot \alpha = X \cdot (Y \cdot \alpha) - Y \cdot (X \cdot \alpha)$.

2 Hopf algebras

Section 1.2 and Section 1.3 are organized to suggest that there are parallels between group representations and Lie algebra representations. There is indeed a common structure underlying both, and the abstraction leads to the definition of a Hopf algebra.

We will keep to kG , $U(\mathfrak{g})$, and their related constructions for running examples in this exposition. Nonetheless, there exist Hopf algebras with behavior distinct from both of these examples. Many of them are *quantum deformations* $U_q(\mathfrak{g})$, which recover $U(\mathfrak{g})$ in the appropriate limit. It is those Hopf algebras that generate much of the interest in the subject. However, for the purposes of this introductory article, we will not elaborate on them.

²Categorically stated – any Lie algebra map $\mathfrak{g} \rightarrow B$, where B is a k -algebra equipped with its commutator Lie bracket, factors uniquely through $\mathfrak{g} \rightarrow U(\mathfrak{g})$.

2.1 Coalgebras and bialgebras

We start by recasting Definition 1.1 in a formulation that lends itself to dualization.

Definition 2.1. A k -algebra is a k -vector space A equipped with k -linear maps $m: A \otimes A \rightarrow A$ and $\eta: k \rightarrow A$, called the *multiplication* and *unit* of A , such that the following diagrams commute:

$$\begin{array}{ccc}
 A \otimes A \otimes A & \xrightarrow{m \otimes \text{id}} & A \otimes A \\
 \text{id} \otimes m \downarrow & & \downarrow m \\
 A \otimes A & \xrightarrow{m} & A
 \end{array}
 \qquad
 \begin{array}{ccccc}
 A \otimes k & \xrightarrow{\cong} & A & \xleftarrow{\cong} & k \otimes A \\
 \searrow \text{id} \otimes \eta & & \uparrow m & & \swarrow \eta \otimes \text{id} \\
 & & A \otimes A & &
 \end{array}$$

These are the *associative law* and *unit law*, respectively. We indeed recover Definition 1.1: the unit $\eta: k \rightarrow A$ is the structure map, and the unit law ensures that $\eta(1)$ is the multiplicative identity in A . For $a, b \in A$, it is customary to notate multiplication by ab instead of $m(a \otimes b)$.

The dual notion of a coalgebra now follows by reversing all arrows:

Definition 2.2. A k -coalgebra is a k -vector space C equipped with k -linear maps $\Delta: C \rightarrow C \otimes C$ and $\varepsilon: C \rightarrow k$, called the *comultiplication* and *counit* of C , such that the following diagrams commute:

$$\begin{array}{ccc}
 C \otimes C \otimes C & \xleftarrow{\Delta \otimes \text{id}} & C \otimes C \\
 \text{id} \otimes \Delta \uparrow & & \uparrow \Delta \\
 C \otimes C & \xleftarrow{\Delta} & C
 \end{array}
 \qquad
 \begin{array}{ccccc}
 C \otimes k & \xleftarrow{\cong} & C & \xrightarrow{\cong} & k \otimes C \\
 \swarrow \text{id} \otimes \varepsilon & & \downarrow \Delta & & \searrow \varepsilon \otimes \text{id} \\
 & & C \otimes C & &
 \end{array}$$

These are the *coassociative law* and *counit law*, respectively. Comultiplication and coassociativity are generally less intuitive than multiplication and associativity. Nonetheless, many important properties of coalgebras, bialgebras, and Hopf algebras lend themselves to verification by computations involving Δ . Such computations rely on *Sweedler notation*, which we summarize as follows: for each $c \in C$, we may write $\Delta(c) = \sum_i c_1^{(i)} \otimes c_2^{(i)}$. We often suppress the index i . For example, the counit law can be expressed as

$$\sum \varepsilon(c_1)c_2 = \sum c_1\varepsilon(c_2) = c,$$

and the coassociativity law can be expressed as

$$\sum c_{11} \otimes c_{12} \otimes c_2 = \sum c_1 \otimes c_2 \otimes c_3 = \sum c_1 \otimes c_{21} \otimes c_{22}.$$

Note that the summations in each of the expressions are not necessarily taken over the same set of indices. In essence, the Sweedler notation assigns a “standard form” to each multitenor, analogous to the way one writes the product xyz in an associative algebra to indicate any one of $(xy)z$ or $x(yz)$.

We work the following exercise and point the reader to [1] or [3] for more details and examples.

Proposition 2.3. *Let (C, Δ, ε) be a coalgebra. For any $c \in C$, we have*

$$\sum \varepsilon(c_1)\varepsilon(c_2)c_3 = c.$$

Proof. Write

$$\sum \varepsilon(c_1)\varepsilon(c_2)c_3 = \sum \varepsilon(c_1)c_2 = c,$$

where the first equality used the coassociativity and the counit law, the second used the counit law directly. \square

Ideally, one reaches a comfort with comultiplication computations such that the above proof is completely natural. In case it seems a bit subtle, we give the argument in full detail. First, there is a k -linear map $f: C \otimes C \otimes C \rightarrow C$ defined on pure tensors by $x \otimes y \otimes z \mapsto \varepsilon(x)\varepsilon(y)z$. The quantity in question is $f(\sum c_1 \otimes c_2 \otimes c_3) = f\left(\sum_{i,j} c_1^{(i)} \otimes c_{21}^{(ij)} \otimes c_{22}^{(ij)}\right)$, by coassociativity. This is $\sum_{i,j} \varepsilon(c_1^{(i)})\varepsilon(c_{21}^{(ij)})c_{22}^{(ij)}$. Summing first by j and using the counit law for $c_2^{(i)}$ yields $\sum_i \varepsilon(c_1^{(i)})c_2^{(i)}$, and now summing by i and using the counit law for c yields c , as desired.

We now give some basic examples and constructions involving (co)algebras that will be useful for later.

Example 2.4. Clearly, k itself has a canonical k -algebra structure. It also has a canonical k -coalgebra structure whose comultiplication Δ sends $1 \mapsto 1 \otimes 1$ and whose counit is the identity.

Example 2.5. Given k -vector spaces V, W , let $\tau_{V,W}: V \otimes W \rightarrow W \otimes V$ denote the *transposition map* given by $v \otimes w \mapsto w \otimes v$. Recall that, given k -algebras (A, m_A, η_A) and (B, m_B, η_B) , their tensor product $A \otimes B$ is naturally a k -algebra. Multiplication is given by $m = (m_A \otimes m_B) \circ (\text{id} \otimes \tau \otimes \text{id})$, i.e. $(a \otimes b)(a' \otimes b') = aa' \otimes bb'$. The unit is given by $1 \mapsto 1_A \otimes 1_B$.

Dually, given k -coalgebras $(C, \Delta_C, \varepsilon_C)$ and $(D, \Delta_D, \varepsilon_D)$, their tensor product $C \otimes D$ is naturally a k -coalgebra. Comultiplication is given by $\Delta = (\text{id} \otimes \tau \otimes \text{id}) \circ (\Delta_C \otimes \Delta_D)$, i.e. $c \otimes d \mapsto \sum c_1 \otimes d_1 \otimes c_2 \otimes d_2$. The counit is given by $c \otimes d \mapsto \varepsilon(c)\varepsilon(d)$.

Example 2.6. Suppose (C, Δ, ε) is a coalgebra and (A, m, η) is an algebra. Consider the k -vector space $\text{Hom}_k(C, A)$. Given $f, g \in \text{Hom}_k(C, A)$, their *convolution product* $f * g \in \text{Hom}_k(C, A)$ is defined by $f * g := m \circ (f \otimes g) \circ \Delta$. Explicitly, this is

$$f * g = (c \mapsto \sum f(c_1)g(c_2)).$$

Check that the convolution product is associative, and $f * (\eta \circ \varepsilon) = (\eta \circ \varepsilon) * f = f$. Then $\text{Hom}_k(C, A)$ forms an algebra with multiplication given by convolution product and unit given by $1 \mapsto \eta \circ \varepsilon$.

We are ready to define bialgebras.

Definition 2.7. A *bialgebra* is an algebra (A, m, η) equipped with a coalgebra structure (A, Δ, ε) such that $\Delta: A \rightarrow A \otimes A$ and $\varepsilon: A \rightarrow k$ are maps of k -algebras, i.e. are compatible with multiplication and respect the unit. Explicitly, the following diagrams commute:

$$\begin{array}{ccc}
H \otimes H & \xrightarrow{\Delta \otimes \Delta} & H \otimes H \otimes H \otimes H \\
\downarrow m & & \downarrow (m \otimes m) \circ (\text{id} \otimes \tau \otimes \text{id}) \\
H & \xrightarrow{\Delta} & H \otimes H
\end{array}
\qquad
\begin{array}{ccc}
H & \xrightarrow{\Delta} & H \otimes H \\
\eta \uparrow & & \eta \otimes \eta \uparrow \\
k & \xrightarrow{\cong} & k \otimes k
\end{array}$$

$$\begin{array}{ccc}
H \otimes H & \xrightarrow{\varepsilon \otimes \varepsilon} & k \otimes k \\
\downarrow m & & \downarrow \cong \\
H & \xrightarrow{\varepsilon} & k
\end{array}
\qquad
\begin{array}{ccc}
H & \xrightarrow{\varepsilon} & k \\
\eta \uparrow & \nearrow \cong & \\
k & &
\end{array}$$

Satisfyingly, the requirement that Δ and ε are maps of k -algebras is equivalent to the requirement that m and η are maps of k -coalgebras. The proof is to write down what the latter means and realize that we have simply redrawn the above diagrams.

Example 2.8. Recall the group algebra kG from Definition 1.3. It has a bialgebra structure with comultiplication and counit defined (on basis elements $g \in G$) by

$$\Delta(g) := g \otimes g \quad \text{and} \quad \varepsilon(g) := 1 \quad \text{for all } g \in G.$$

Example 2.9. Recall the universal enveloping algebra $U(\mathfrak{g})$ from Section 1.3. It has a bialgebra structure with comultiplication and counit defined (on generators $\xi \in \mathfrak{g}$) by

$$\Delta(\xi) := \xi \otimes 1 + 1 \otimes \xi \quad \text{and} \quad \varepsilon(\xi) := 0 \quad \text{for all } \xi \in \mathfrak{g}.$$

The reader may wish to verify the claims being made in Examples 2.8 and 2.9: coassociativity, counit law, compatibility with multiplication and unit.

At this point, we have enough structure to make good on part of our promise from the outset of this section. Suppose $(H, m, \eta, \Delta, \varepsilon)$ is a bialgebra. Using the algebra structure on H , we can speak of H -modules (representations) in the sense of Definition 1.2.³ We denote the category of H -modules by \mathbf{Mod}_H , and the category of finite-dimensional H -modules by $\mathbf{f.Mod}_H$.

Owing to the coalgebra structure on H , the category of H -modules distinguishes itself from the category of modules over an arbitrary k -algebra. First, given $V, W \in \mathbf{Mod}_H$, there is a natural H -module structure on $V \otimes W$. The action of H is given by

$$h \cdot (v \otimes w) := \sum h_1 v \otimes h_2 w.$$

It follows from coassociativity of Δ that the action of H on $V \otimes W$ is associative, as required. Second, k itself is naturally an H -module, with the action of H on k determined by

$$h \cdot 1 := \varepsilon(h).$$

³Dually, there is a notion of an *H-comodule*, given by a *coaction* of H on a k -vector space. We won't need this, though.

These two properties are compatible in the sense that the canonical isomorphisms

$$V \otimes k \cong V \cong k \otimes V$$

are not just isomorphisms of k -vector spaces, but isomorphisms of H -modules: they respect H -actions. Indeed, this follows from the counit law.

2.2 Hopf algebras

Definition 2.10. A *Hopf algebra* is a bialgebra H in which the identity map is convolution-invertible in $\text{Hom}_k(H, H)$, with inverse S . (See Example 2.6.) Explicitly, this means that for all $h \in H$,

$$\sum S(h_1)h_2 = \sum h_1S(h_2) = \eta(\varepsilon(h)) = \varepsilon(h)1_H. \quad (2.2.1)$$

The element S is called the *antipode*.

Observe that the antipode of a Hopf algebra is unique because it is the inverse of an element in the algebra $\text{Hom}_k(H, H)$.

Example 2.11. The group bialgebra kG is a Hopf algebra with antipode $S: kG \rightarrow kG$ defined by

$$S(g) = g^{-1}.$$

Example 2.12. The bialgebra $U(\mathfrak{g})$ is a Hopf algebra with antipode $S: U(\mathfrak{g}) \rightarrow U(\mathfrak{g})$ defined on the generators $\xi \in \mathfrak{g}$ by

$$S(\xi) = -\xi.$$

Consider the above two examples along with the comultiplications and counits defined in Examples 2.8 and 2.9. Classically, a Lie algebra \mathfrak{g} was the tangent space at the identity element of a matrix group G , i.e. a “linearization” or “derivative” of G , in some sense. We see this intuition reflected in the corresponding Hopf algebra structures of kG and $U(\mathfrak{g})$.

As Example 2.11 suggests, we can think of the antipode of a Hopf algebra as a kind of inversion operator. Indeed, one can show that, in any Hopf algebra, the antipode S satisfies $S(gh) = S(h)S(g)$. In fact, we have the following:

Proposition 2.13. *The antipode $S: H \rightarrow H$ of a Hopf algebra H is both an antihomomorphism of algebras and an antihomomorphism of coalgebras. Explicitly, for any $g, h \in H$,*

$$S(hg) = S(g)S(h), \quad S(1_H) = 1_H,$$

$$\Delta(S(h)) = \sum S(h_2) \otimes S(h_1), \quad \varepsilon(S(h)) = \varepsilon(h).$$

The proof of Proposition 2.13 amounts to some clever Sweedler-type computations, which we omit. See [1] for details.

Corollary 2.13.1. *If a Hopf algebra H is commutative as an algebra or cocommutative as a coalgebra (i.e. $\tau \circ \Delta = \Delta$), then the antipode S is an involution.*

We give a brief sketch of the proof: if H is commutative, then Equation 2.2.1 yields $\sum S(h_2)h_1 = \varepsilon(h)1_H$. Using this along with the identities in Proposition 2.13, one computes the convolution $S * S^2 \in \text{Hom}_k(H, H)$ and arrives at $\eta \circ \varepsilon$, forcing S^2 to be the identity on H . The cocommutative case follows a similar argument.

The examples kG and $U(\mathfrak{g})$ are both cocommutative, and their respective antipodes are indeed involutions. In general, however, a Hopf algebra need not have involutive antipode. In Section 2.3, we will see that if H is quasitriangular, then the square of its antipode is well-behaved.

We now describe a construction that will be important in Section 3.3.

Example 2.14. If a Hopf algebra $(H, m, \eta, \Delta, \varepsilon, S)$ is finite-dimensional (like kG for a finite group G), then the linear dual H^* has a Hopf algebra structure $(H^*, \Delta^*, \eta', m^*, \varepsilon', S^*)$. Here, $\Delta^*: (H \otimes H)^* \rightarrow H^*$, $m^*: H^* \rightarrow (H \otimes H)^*$ and $S^*: H^* \rightarrow H^*$ are the duals of Δ , m , and S , where we use the finite-dimension assumption on H to canonically identify $(H \otimes H)^*$ with $H^* \otimes H^*$. (Namely, if $h_1, \dots, h_n \in H$ is a basis, then the isomorphism sends $(h_i \otimes h_j)^\vee \mapsto h_i^\vee \otimes h_j^\vee$.) The unit η' is given by $1 \mapsto \varepsilon$, and the counit ε' is given by $f \mapsto f(1_H)$.

For a concrete example, let $(kG^*, m_{kG^*}, \eta_{kG^*}, \Delta_{kG^*}, \varepsilon_{kG^*}, S_{kG^*})$ denote the dual of the group Hopf algebra $(kG, m, \eta, \Delta, \varepsilon, S)$ for a finite group G . Take the standard basis $\{g \in G\}$ for kG , with dual basis $\{g^\vee\}$. For any $g, h \in G$, we have

$$m_{kG^*}(g^\vee \otimes h^\vee) = (g \otimes h)^\vee \circ \Delta = \begin{cases} 0 & g \neq h \\ g^\vee & g = h \end{cases},$$

$$\Delta(f) = \sum_{g, h \in G} f(gh)(g^\vee \otimes h^\vee) \quad \text{for any } f \in kG^*,$$

$$1_{kG^*} = \sum_{g \in G} g^\vee, \quad \varepsilon_{kG^*}(g^\vee) = g^\vee(1_G) = \begin{cases} 0 & g \neq 1_G \\ 1 & g = 1_G \end{cases},$$

$$S_{kG^*}(g^\vee) = g^\vee \circ S = (g^{-1})^\vee.$$

We leave it to the reader to check that kG^* is a Hopf algebra as such.

Finally, we consider the category Mod_H . Earlier, we saw that the bialgebra structure on H allows for an H -module structure on the tensor product of two H -modules. Now, the antipode on H allows for a natural H -module structure on the linear dual of an H -module. Suppose H acts on V . Then H acts on V^* by

$$h \cdot f = (v \mapsto f(S(h) \cdot v)).$$

The antihomomorphism property of S ensures that the action is associative. In the cases kG and $U(\mathfrak{g})$, we indeed recover Definitions 1.5 and 1.9.

The category Mod_H now has both of the desired properties presented in Section 1: tensors and duals. Here is another property it generalizes.

Definition 2.15. A Hopf algebra H is itself canonically an H -module via the *adjoint action*, given by

$$h \cdot g := \sum h_1 g S(h_2).$$

The adjoint action is notated $\text{ad}_h(g)$.

In the case of kG , the adjoint action is conjugation: for basis elements $h, g \in G$, we have $\text{ad}_h(g) = hgh^{-1}$. In the case of $U(\mathfrak{g})$, the adjoint action already has a name in Lie theory, and indeed coincides with the above definition: for generators $\xi, \eta \in \mathfrak{g}$, we have $\text{ad}_\xi(\eta) = \xi\eta - \eta\xi = [\xi, \eta]$.

2.3 Quasitriangular and ribbon Hopf algebras

We now define two important extensions of the Hopf algebra structure. This section may seem rather opaque, but we promise that it will feel more motivated once the diagrammatic theory is introduced in Section 3.2.

Definition 2.16. A *quasitriangular Hopf algebra* (also known as a *quantum group*) is a Hopf algebra H along with a choice of invertible element $R \in H \otimes H$ such that:

- (i) $(\tau \circ \Delta)(h) = R \cdot \Delta(h) \cdot R^{-1}$ for all $h \in H$,
- (ii) $(\Delta \otimes \text{id})(R) = R_{13}R_{23}$,
- (iii) $(\text{id} \otimes \Delta)(R) = R_{13}R_{12}$.

Here, the terms $R_{ij} \in H \otimes H \otimes H$ are given by $R_{12} = R \otimes 1_H$, $R_{23} = 1_H \otimes R$, and if we write $R = \sum_i R_i^{(1)} \otimes R_i^{(2)}$, then (with indices suppressed) $R_{13} = \sum R^{(1)} \otimes 1_H \otimes R^{(2)}$.

Observe that any cocommutative Hopf algebra, such as kG or $U(\mathfrak{g})$, can trivially be given a quasitriangular structure with $R = 1_H \otimes 1_H$. We defer a nontrivial example to Section 3.3 when we discuss the quantum double of the group algebra.

The quasitriangular structure R interacts nicely with the antipode S and the counit ε ; in fact S is invertible in a quasitriangular Hopf algebra. The identities and their details can be found in [3]. We content ourselves with following two:

Proposition 2.17 (Yang-Baxter relation). *The element R satisfies*

$$R_{12}R_{13}R_{23} = R_{23}R_{13}R_{12}.$$

Proposition 2.18. *In a quasitriangular Hopf algebra H , the element $u := \sum S(R^{(2)})R^{(1)}$ is invertible, and for all $h \in H$,*

$$S^2(h) = uhu^{-1}.$$

We can interpret Proposition 2.18 as a way to “salvage” Corollary 2.13.1 in case H is not (co)commutative: even if the antipode is not involutive, its square is well-behaved (an inner automorphism), at least for quasitriangular Hopf algebras. The proofs of these properties are computations, which we defer again to [3].

Finally, we define one more class of Hopf algebras. The definition will seem opaque and unmotivated, but we include it anyways: it will serve as a point of reference for Definition 3.10 on ribbon *categories*, which are needed to correctly formulate our method for producing quantum knot invariants in Section 3.3. They also enrich the diagrammatic theory in Section 3.2.

Definition 2.19. A *ribbon Hopf algebra* is a quasitriangular Hopf algebra H for which there exists an element $\nu \in H$ lying in the center of H such that

$$\nu^2 = uS(u), \quad S(\nu) = \nu, \quad \varepsilon(\nu) = 1, \quad \Delta(\nu) = (R_{21}R_{12})^{-1}(\nu \otimes \nu).$$

3 Categories and Knots

3.1 Monoidal categories

The category of H -modules for a Hopf algebra fits into a general class of categories.

Definition 3.1. A *strict monoidal category* is a category \mathcal{C} equipped with a functor $\otimes: \mathcal{C} \times \mathcal{C} \rightarrow \mathcal{C}$ and a *unit object* $\underline{1} \in \mathcal{C}$ such that, for any objects V, W, Z and morphisms f, g, h in \mathcal{C} , we have

$$(V \otimes W) \otimes Z = V \otimes (W \otimes Z), \quad (f \otimes g) \otimes h = f \otimes (g \otimes h) \quad (3.1.1)$$

and

$$V \otimes \underline{1} = V = \underline{1} \otimes V, \quad f \otimes \text{id}_{\underline{1}} = f = \text{id}_{\underline{1}} \otimes f. \quad (3.1.2)$$

We dispose of a technicality before proceeding. There is a more general notion of a *monoidal category*, for which the left equalities 3.1.1 and 3.1.2 are replaced by natural isomorphisms $\Phi_{V,W,Z}: (V \otimes W) \otimes Z \rightarrow V \otimes (W \otimes Z)$ as well as $\ell_V: V \otimes \underline{1} \rightarrow V$ and $r_V: \underline{1} \otimes V \rightarrow V$ satisfying certain compatibility conditions (keywords: pentagon diagram, triangle diagram). Monoidal categories are the correct setting for most of what follows. For example, consider the prototypical monoidal category, the category \mathbf{Vec}_k of k -vector spaces with the usual tensor product, unit object k , and the usual canonical isomorphisms $(V \otimes W) \otimes Z \cong V \otimes (W \otimes Z)$ and $V \otimes k \cong V \cong k \otimes V$. It would be incorrect to declare (for example) that $V \otimes k$ and V are literally the same object, so \mathbf{Vec}_k is not strict monoidal.

However, notating calculations in a monoidal category quickly becomes cumbersome, so it is customary to suppress Φ , ℓ , and r . By a so-called *coherence theorem* of MacLane, nothing is lost in doing so, and for all practical purposes we may pretend like we are working in the strict setting. We readily adopt this convention for everything that follows.

Example 3.2. Suppose $(H, m, \eta, \Delta, \varepsilon)$ is a bialgebra. Then \mathbf{Mod}_H is a monoidal category. Indeed, we have seen that if H acts on V and W , then the coalgebra structure determines an action of H on $V \otimes W$, so we can take tensor products in \mathbf{Mod}_H . Moreover, we have a unit object k with canonical isomorphisms $V \otimes k \cong V \cong k \otimes V$ in \mathbf{Mod}_H .

In Section 2, we progressively “upgraded” from algebra to bialgebra to Hopf algebra to quasitriangular Hopf algebra and so on. We’ll parallel this by progressively “upgrading” our category to obtain the corresponding generalizations.

3.1.1 Rigid categories

Definition 3.3. A *rigid category* is a monoidal category \mathcal{C} such that each object $V \in \mathcal{C}$ is equipped with a triple $(V^*, \text{ev}_V, \text{coev}_V)$ where V^* is an object of \mathcal{C} and $\text{ev}_V: V^* \otimes V \rightarrow \underline{1}$ and $\text{coev}_V: \underline{1} \rightarrow V \otimes V^*$ are morphisms such that

$$(\text{id} \otimes \text{ev}_V) \circ (\text{coev}_V \otimes \text{id}) = \text{id}_V \quad \text{and} \quad (\text{ev}_V \otimes \text{id}) \circ (\text{id} \otimes \text{coev}_V) = \text{id}_{V^*}. \quad (3.1.3)$$

The object V^* is called the *dual* of V , and the morphisms ev_V and coev_V are called *evaluation* and *coevaluation*, respectively.

The prototypical rigid category is $\mathbf{f.Vec}_k$, the category of finite-dimensional k -vector spaces, where V^* , ev_V , and coev_V take their usual meanings:

$$V^* = \text{Hom}_k(V, k), \quad \text{ev}_V(\phi \otimes v) = \phi(v), \quad \text{coev}_V(1) = \sum_{i=1}^n v_i \otimes v_i^\vee,$$

where $v_1, \dots, v_n \in V$ is a chosen basis and $v_1^\vee, \dots, v_n^\vee \in V^*$ is the dual basis. (Recall that coev_V is independent of this choice.)

Example 3.4. Suppose $(H, m, \eta, \Delta, \varepsilon, S)$ is a Hopf algebra. Then $\mathbf{f.Mod}_H$ is a rigid category with duals and (co)evaluation given by those of the underlying k -vector spaces. Indeed, we saw that if H acts on V , then the antipode on H determines an action of H on V^* , so we can take duals in $\mathbf{f.Mod}_H$.

If $f: V \rightarrow W$ is a morphism in a rigid category, the *dual morphism* $f^*: W^* \rightarrow V^*$ is defined by

$$f^* = (\text{ev}_W \otimes \text{id}) \circ (\text{id} \otimes f \otimes \text{id}) \circ (\text{id} \otimes \text{coev}_V).$$

In particular, given a rigid category \mathcal{C} , there is a *dualizing functor* $(-)^*: \mathcal{C} \rightarrow \mathcal{C}^{\text{op}}$ sending objects and morphisms to their duals. A natural question to ask of any rigid category is whether the double dual is naturally isomorphic to the identity functor, as one would expect from linear algebra.

In the literature, the categories of Definition 3.3 are often called *left rigid*. Indeed, there is a notion of a *right dual*, which is an object V^* along with morphisms $\overline{\text{ev}}_V: V \otimes V^* \rightarrow \underline{1}$ and $\overline{\text{coev}}_V: \underline{1} \rightarrow V^* \otimes V$ satisfying

$$(\overline{\text{ev}}_V \otimes \text{id}) \circ (\text{id} \otimes \overline{\text{coev}}_V) = \text{id}_V, \quad \text{and} \quad (\text{id} \otimes \overline{\text{ev}}_V) \circ (\overline{\text{coev}}_V \otimes \text{id}) = \text{id}_{V^*}. \quad (3.1.4)$$

Another question to ask of a rigid category is whether it has right duals and whether the left and right duals agree.

As we will see, the answer to both questions is yes under certain extra conditions.

3.1.2 Braided categories

In \mathbf{Vec}_k , there is a canonical isomorphism $V \otimes W \rightarrow W \otimes V$ given by the transposition map τ . This is the next property we wish to categorify. First, note that τ has the following characterization: the map $V \otimes W \otimes Z \rightarrow W \otimes Z \otimes V$ given by transposing V, W and then V, Z is same as the map given by a single transposition applied to V and $W \otimes Z$. This leads us to:

Definition 3.5. A *braided category* is a monoidal category \mathcal{C} equipped with a natural isomorphism $\Psi: \otimes \rightarrow \otimes^{\text{op}}$ such that, for any objects $V, W, Z \in \mathcal{C}$,

$$\Psi_{V, W \otimes Z} = (\Psi_{V, Z} \otimes \text{id}) \circ (\text{id} \otimes \Psi_{V, W}) \quad \text{and} \quad \Psi_{V \otimes W, Z} = (\Psi_{V, Z} \otimes \text{id}) \circ (\text{id} \otimes \Psi_{W, Z}). \quad (3.1.5)$$

As a sanity check, we have:

Proposition 3.6. *For any object V in a braided category,*

$$\Psi_{V, \underline{1}} = \text{id}_V = \Psi_{\underline{1}, V}.$$

Proof. We have $\Psi_{V,\underline{1}} = \Psi_{V,\underline{1}\otimes\underline{1}} = (\Psi_{V,\underline{1}} \otimes \text{id}) \circ (\text{id} \otimes \Psi_{V,\underline{1}}) = \Psi_{V,\underline{1}} \circ \Psi_{V,\underline{1}}$, where we are viewing the far left and right sides as morphisms of V . The first and third equalities use 3.1.2 and the second equality uses 3.1.5. But $\Psi_{V,\underline{1}}$ is an isomorphism, so it must be the identity. Similar reasoning applies for $\Psi_{\underline{1},V}$. \square

Proposition 3.7 (Yang-Baxter relation). *For any objects V, W, Z in a braided category, we have*

$$(\Psi_{W,Z} \otimes \text{id}) \circ (\text{id} \otimes \Psi_{V,Z}) \circ (\Psi_{V,W} \otimes \text{id}) = (\text{id} \otimes \Psi_{V,W}) \circ (\Psi_{V,Z} \otimes \text{id}) \circ (\text{id} \otimes \Psi_{W,Z}).$$

It is not hard to prove Proposition 3.7 directly using 3.1.5 and naturality of the braiding. However, we defer a proof until Section 3.2 when we can give a visual demonstration. In any case, in light of the similarity with Proposition 2.17, the following proposition may not be surprising:

Proposition 3.8. *Suppose $(H, m, \eta, \Delta, \varepsilon, S, R)$ is a quasitriangular Hopf algebra. Then Mod_H is a braided category, with braiding $\Psi_{V,W}: V \otimes W \rightarrow W \otimes V$ given by*

$$v \otimes w \mapsto \tau(R \cdot (v \otimes w)) = \sum R^{(2)}w \otimes R^{(1)}v. \quad (3.1.6)$$

The proof is a computation, which we omit. The computation shows that the implication also goes the other way: any braiding on Mod_H is necessarily given by 3.1.6 for some $R \in H \otimes H$ satisfying the conditions of Definition 2.16.

It turns out that we are now able to answer our question about double duals:

Proposition 3.9. *For any object V in a rigid braided category, there exists a canonical isomorphism $\mathbf{u}_V: V \rightarrow V^{**}$ given by*

$$\mathbf{u}_V := (\text{ev}_V \otimes \text{id}) \circ (\Psi_{V,V^*} \otimes \text{id}) \circ (\text{id} \otimes \text{coev}_{V^*})$$

with inverse

$$\mathbf{u}_V^{-1} := (\text{id} \otimes \text{ev}_{V^*}) \circ (\Psi_{V^{**},V} \otimes \text{id}) \circ (\text{id} \otimes \text{coev}_V).$$

We defer the proof until Section 3.2.

3.1.3 Ribbon categories

We introduce one more categorical specialization.

Definition 3.10. A *ribbon category* is a rigid braided category \mathcal{C} equipped with a natural isomorphism $\theta: \text{id} \rightarrow \text{id}$, called the *twist*, such that

$$\theta_{V^*} = (\theta_V)^*, \quad \theta_{\underline{1}} = \text{id}_{\underline{1}}, \quad \theta_{V \otimes W} = \Psi_{W,V}^{-1} \circ \Psi_{V,W}^{-1} \circ (\theta_V \otimes \theta_W). \quad (3.1.7)$$

Compare Definitions 3.10 and 2.19. It is not surprising that:

Proposition 3.11. *If $(H, m, \eta, \Delta, \varepsilon, S, R, \nu)$ is a ribbon Hopf algebra, then the category $f.\text{Mod}_H$ is ribbon, where the morphism $\theta_V: V \rightarrow V$ is given by the action of ν .*

We are now also able to answer our question about right duals:

Proposition 3.12. *For any object V in a ribbon category, the dual V^* is a right dual, with*

$$\overline{\text{ev}}_V := \text{ev}_V \circ (\text{id} \otimes \theta_V^{-1}) \circ \Psi_{V,V^*}, \quad \overline{\text{coev}}_V := \Psi_{V,V^*} \circ (\theta_V^{-1} \otimes \text{id}) \circ \text{coev}_V.$$

We omit proofs of these propositions but give visual intuition for Proposition 3.12 in Section 3.2. See [3] for details.

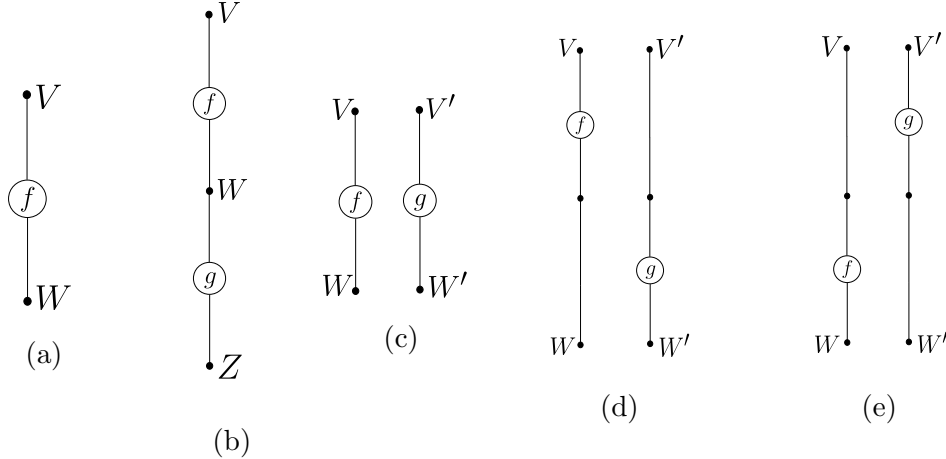

Figure 1: Morphisms and basic operations

3.2 The diagrammatic theory

In this section and the next, we will make light reference to notions from knot theory, like tangles, Reidemeister moves, and writhe. The reader may consult [3] or [2] for a more detailed review of the relevant knot theoretic concepts.

The basic idea behind the diagrammatic theory is to represent morphisms in a braided monoidal category with tangles (i.e. possibly multi-strand, open-ended knot diagrams with fixed endpoints). This allows one to use spatial intuition to deduce or prove algebraically tedious identities. It is also rather elegant in its own right.

First suppose \mathcal{C} is any category. We may represent any morphism $f: V \rightarrow W$ pictorially as in Figure 1(a). Nodes are labeled by objects, and segments represent morphisms. We read from top to bottom. The identity morphism is special, and is indicated by an unlabeled segment. The composition of two morphisms is represented by vertical concatenation, as in Figure 1(b).

Now suppose \mathcal{C} is monoidal. The idea is to represent \otimes using horizontal concatenation. Given two morphisms $f: V \rightarrow W$ and $g: V' \rightarrow W'$, the morphism $f \otimes g: V \otimes V' \rightarrow W \otimes W'$ is shown in Figure 1(c). The unit object $\underline{1}$ is usually left unindicated in light of Equation 3.1.2. Functoriality of \otimes implies that all three of Figures 1(c), 1(d), and 1(e) represent the same morphism. Informally, this simply means that we can freely “slide” morphisms along unlabeled segments.

Now suppose \mathcal{C} is rigid. We introduce special “cup” and “cap” symbols for evaluation and coevaluation, keeping in mind that $\underline{1}$ is left unindicated. See Figures 2(a) and 2(b). Keep in mind that functoriality of \otimes still applies to ev_V and coev_V ; namely, we can slide cups and caps up and down pairs of parallel unlabeled segments. The (co)evaluation axioms 3.1.3 say that we can “smooth out bends”. See Figure 2(c).

Now suppose \mathcal{C} is rigid braided. We represent the braiding map $\Psi_{V,W}$ using the crossing shown in Figure 3(a), and its inverse $\Psi_{V,W}^{-1}$ using the crossing with opposite over and under strand. The fact that they are inverses tells us that we can perform the braid cancellation moves in Figure 3(b), which are the Type II Reidemeister moves from knot theory.

Much like functoriality of \otimes allows us to slide morphisms up and down, naturality of Ψ

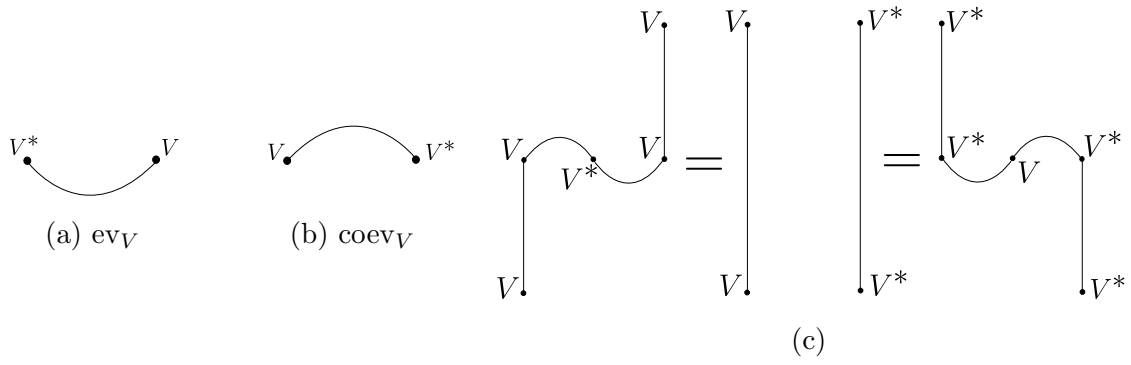

Figure 2: (Co)evaluation maps and cup/cap cancellation

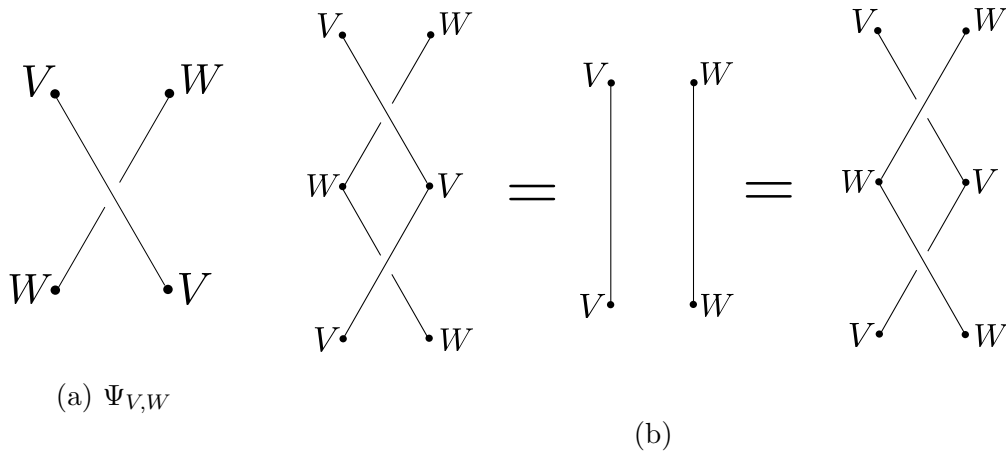

Figure 3: Braid and braid cancellation

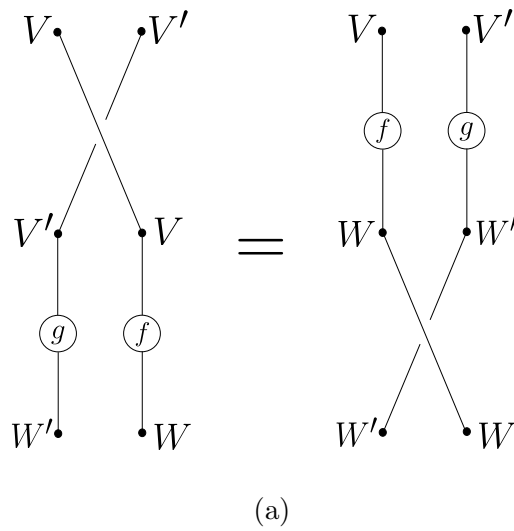

Figure 4: Braid naturality

allows us to “pull morphisms through crossings”. See Figure 4(a).

Roughly speaking, Proposition 3.6 tells us that the vertical alignment of nodes in our picture is irrelevant so long as the relative order of the nodes in each row is correct. Indeed, we can think of moving nodes horizontally as simply braiding with $\underline{1}$.

Example 3.13. We show that Figures 5(a) and 5(d) represent the same morphism $V \rightarrow V \otimes V^* \otimes V$. First, we use 3.1.5 to rewrite the two braidings in Figure 5(a) as single braiding between V and $V \otimes V^*$, and then redraw the cap so that $\underline{1}$ is not hidden. This yields 5(b). Then we apply naturality to pull the coevaluation map through the crossing, yielding 5(c). Finally, we use Proposition 3.6 and to ignore the braiding $\Psi_{V,\underline{1}}$, and then change the coevaluation back into the cap.

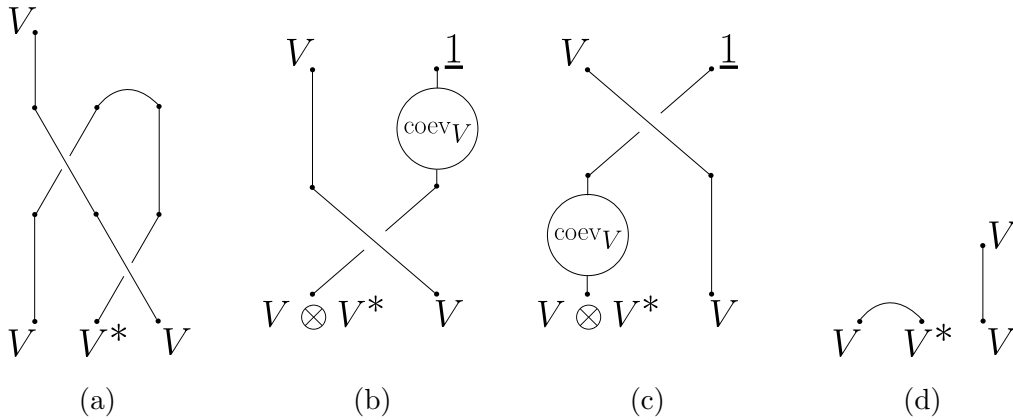

Figure 5

Example 3.14. Let us prove Proposition 3.7, that the braiding Ψ satisfies the Yang-Baxter relation. The proof is given in Figure 6, where the aim is to prove that the first and last diagrams represent the same morphism; the steps are very similar to those of Example 3.13. Pictorially, the Yang-Baxter relation amounts to the Type III Reidemeister move from knot theory.

Example 3.15. Let us prove Proposition 3.9, that the morphisms u_V and u_V^{-1} are in fact inverse isomorphisms between V and its double dual V^{**} . We will only check that $u_V^{-1} \circ u_V = \text{id}_V$, the other verification being similar. Pictorially, $u_V^{-1} \circ u_V$ is illustrated in Figure 7(a). Unlike in the previous examples, we will be fast and loose with the steps. Roughly speaking, the step from 7(a) to 7(b) uses naturality to pull a strand under a large part of the picture; the step from 7(b) to 7(c) uses sliding moves and a cup/cap cancellation from Figure 2(c); the step from 7(c) to 7(d) uses Example 3.13; and the final step uses another cup/cap cancellation.

The previous example makes the connection to knot theory rather explicit: roughly speaking, we can manipulate the pictures as if the segments were components of a tangle, without changing the morphism it represents. That said, the reader may not find the diagrammatic calculus rigorous enough for proof. This is fair. There are indeed caveats and

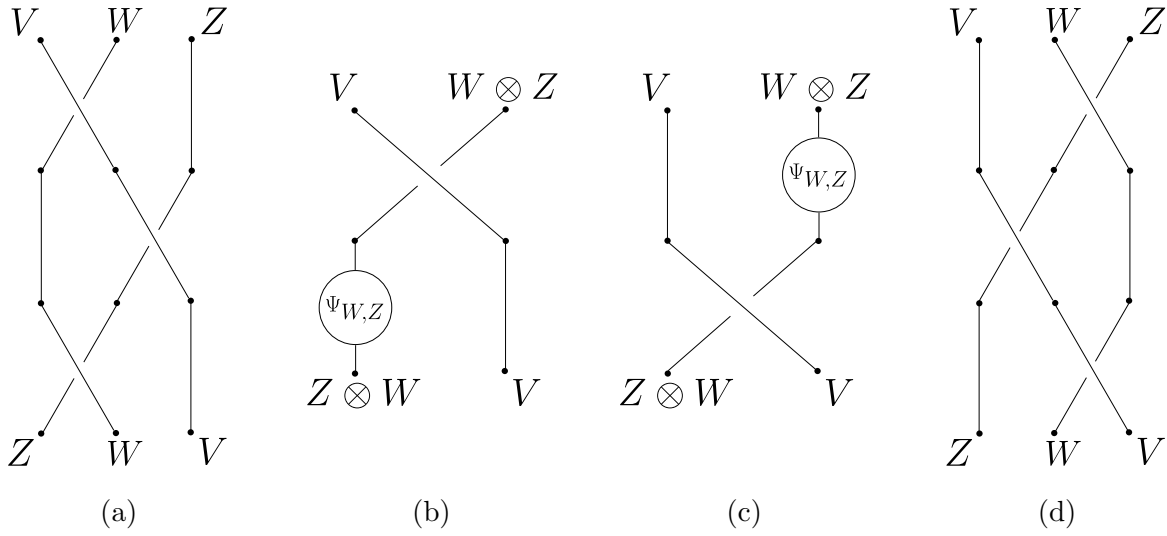

Figure 6: Yang-Baxter relation, pictorially

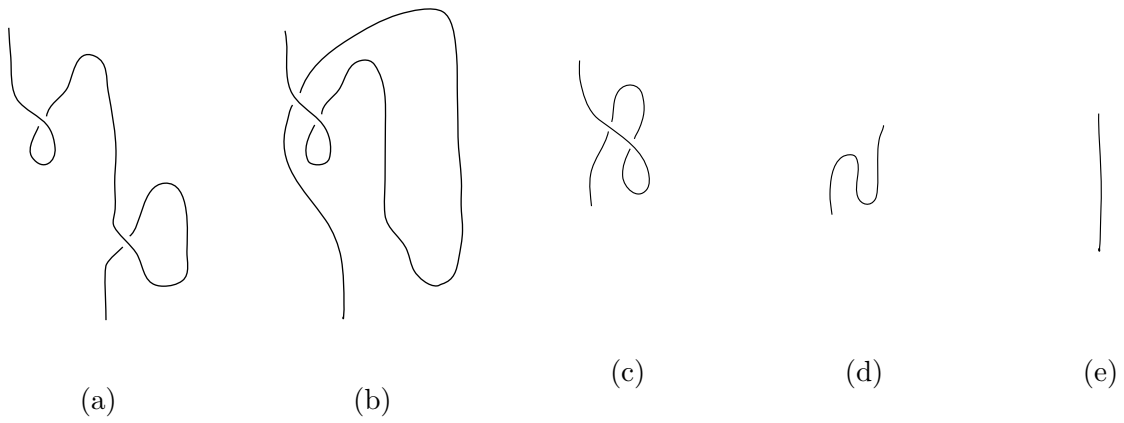

Figure 7: Computing $u_V^{-1} \circ u_V = \text{id}_V$ pictorially

details that deserve care – for example, the morphism that a diagram represents is not a full knot invariant, but rather *framed* one: we are not allowed to change the *writhe*. We will not elaborate on the details, however, as the aim is only to give a general sense of the idea. Rigorous or not, the visual method is appealing – purely algebraic approaches to the theory do not make it nearly as easy to see at a glance why the claims like Proposition 3.9 should be true in the first place.

In the spirit of unrigorous intuition-building, we consider the case where \mathcal{C} is ribbon, but do not prove anything. Instead, we simply state what the pictures should be and check that they make sense knot-theoretically.

The pictures for the twist map θ_V and its inverse θ_V^{-1} are given in Figure 8(a). Perhaps unsurprisingly, they are literally twists. Pictorially, the third requirement in Definition 3.10 is given by Figure 8(c). We promised in Section 3.1.3 to give visual intuition for Proposition 3.12. This is shown in Figure 8(d). One can check that the equivalences claimed in Figures 8(c) and 8(d) do indeed hold if we pretend they are tangle diagrams up to isotopy and writhe-preserving Reidemeister moves.

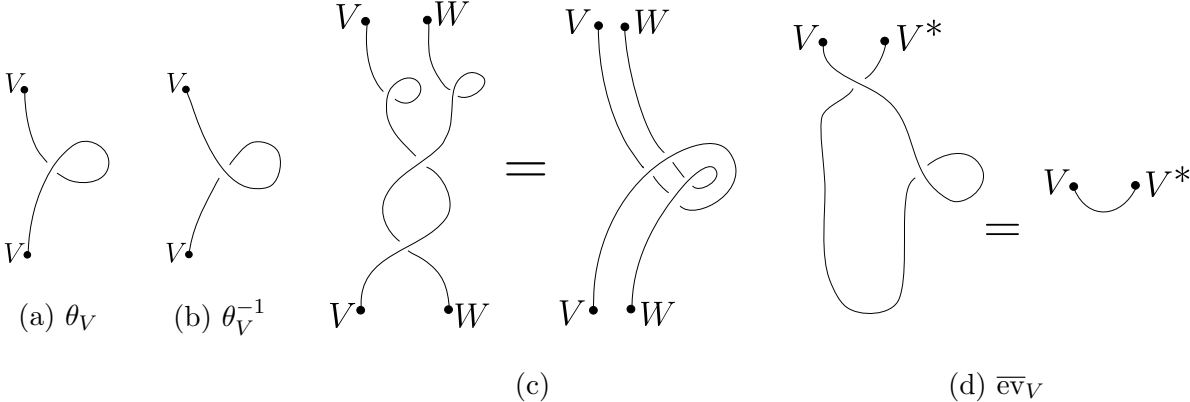

Figure 8: The twist map θ_V

Our diagrammatic calculus now includes the twist θ_V as well as a new cup and cap for \overline{ev}_V and \overline{coev}_V , respectively. We add one more feature. Consider a morphism “built” out of *elementary morphisms* (i.e. braidings, cups, caps, unlabeled segments, and tensors thereof). Observe that for each component (i.e. strand) of such a diagram, each node along that component is labeled either V or V^* for some object V . The reader may verify that there is a unique way to *orient* the component such that the tangent vector to the component at each node is downward-pointing at each node labeled V and upward-pointing at each node labeled V^* . For example, cups and caps get the orientations shown in Figure 9.

Conversely, an orientation dictates a labeling of the nodes with V and V^* . Oriented diagrams will be convenient when we discuss quantum knot invariants below.

At this point, we have seen the basic ideas and constructions needed for main example of this article. For more details on the diagrammatic theory, we encourage the reader to consult [3]. The reader may also consult [4], which contains a more expansive, thorough, and precise treatment (though with notational conventions differing from ours).

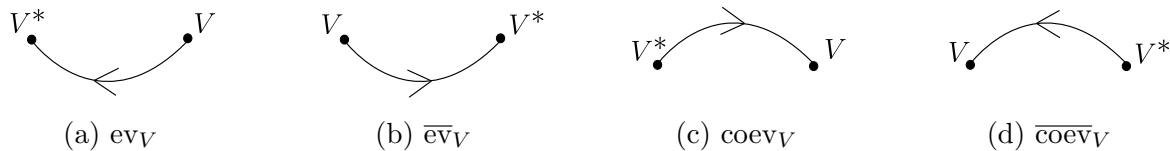
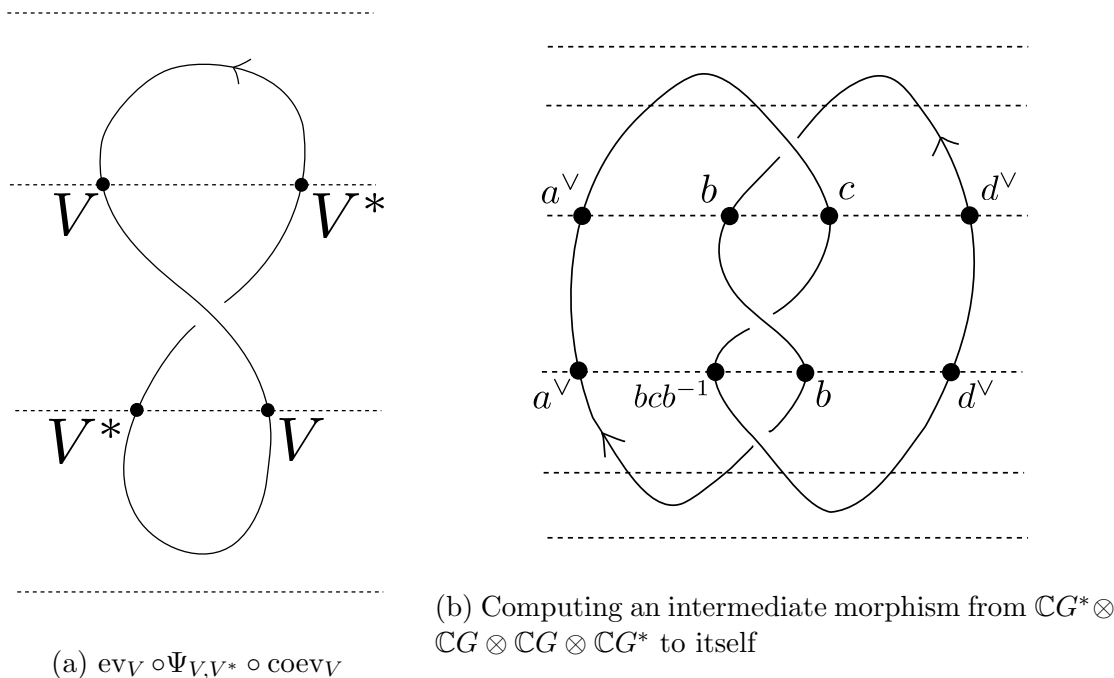

Figure 9: Oriented cups and caps in a ribbon category

3.3 Knot invariants

We have seen that knot theory can help us do algebra. Conversely, algebra can help us do knot theory. This idea led to the development of *quantum knot invariants*, and the idea is as follows.

- (i) Given an *oriented* knot diagram, read it as a morphism $\underline{1} \rightarrow \underline{1}$ in a ribbon category \mathcal{C} .
- (ii) Pick a ribbon Hopf algebra H and an H -module V and put $\mathcal{C} = \mathbf{Mod}_H$.
- (iii) Decompose the knot diagram as a composition of elementary morphisms and label the nodes of diagram with V and V^* as appropriate. See Figure 10(a).
- (iv) We now have a morphism $k \rightarrow k$ in \mathbf{Mod}_H . It is necessarily scalar multiplication by some constant, which is our invariant.



(b) Computing an intermediate morphism from $\mathbb{C}G^* \otimes \mathbb{C}G \otimes \mathbb{C}G \otimes \mathbb{C}G^*$ to itself

Figure 10

Step (iii) is possible for any diagram because our category is ribbon. For example, the unknot diagram (a circle with no crossings) cannot be decomposed as such unless we have

both left and right (co)evaluation maps. Conveniently, the orientation on the knot fixes a choice of labeling – without it, we would not be able to tell between ev_V and $\overline{\text{ev}}_V$ (for example) and there are two possible labelings.

To illustrate the method, we give the simplest concrete example within the scope of this article that produces an interesting knot invariant: namely, given a knot K , the invariant is the number of group homomorphisms from the knot group $\pi_1(S^3 \setminus K)$ to a fixed group G .⁴

For this, we will need a more “interesting” Hopf algebra than kG . Recall that kG is cocommutative, and the obvious braiding given by $R := 1_G \otimes 1_G$ yields $\Psi_{V,W} = \Psi_{W,V}^{-1}$. One can then check that knot invariants produced using kG -modules will be unable to distinguish between two knots that differ only in over/under crossing data.

Instead, we will take the *Drinfeld double* of kG . This is a general construction that takes any finite-dimensional Hopf algebra H and produces quasitriangular Hopf algebra $D(H)$ with nontrivial braiding. First, recall from Example 2.14 that H^* is canonically a Hopf algebra.

Definition 3.16. The *Drinfeld double* is the k -vector space $D(H) := H^* \otimes H$ endowed with the following Hopf algebra structure. The coalgebra structure on $D(H)$ is given by the canonical product coalgebra structure (see Example 2.5), namely

$$\Delta(\phi \otimes h) := \sum \phi_1 \otimes h_1 \otimes \phi_2 \otimes h_2 \quad \text{and} \quad \varepsilon(\phi \otimes h) := \varepsilon_{H^*}(\phi)\varepsilon_H(h).$$

Multiplication, on the other hand, is defined by

$$(\phi \otimes h)(\psi \otimes g) := \sum \psi_1(S_H(h_1))\psi_3(h_3)(\phi\psi_2 \otimes h_2g).$$

The multiplicative unit is $1_{H^*} \otimes 1_H$, and the antipode is given by

$$S(\phi \otimes h) = (1_{H^*} \otimes S_H(h))(S_{H^*}^{-1}(\phi) \otimes 1_H).$$

The Drinfeld double is quasitriangular, where if v_1, \dots, v_n is any basis of H with dual basis $v_1^\vee, \dots, v_n^\vee$,

$$R := \sum_{i=1}^n (v_i^\vee \otimes 1_H) \otimes (1_{H^*} \otimes v_i).$$

For us, the relevant example is $H = \mathbb{C}G$, the complex group algebra. (Diligent readers wishing to verify that $D(H)$ satisfies all the axioms of a quasitriangular Hopf algebra may find more use in verifying this special case.) Multiplication in $D(\mathbb{C}G)$ is given for any $a, b, h, g \in G$ by

$$(a^\vee \otimes h)(b^\vee \otimes g) := a^\vee(hbh^{-1})^\vee \otimes hg.$$

Notice that this formula resembles that of the multiplication formula in a semidirect product of groups. The reader may wish to consult [3] or search for references on *crossed products* and *crossed modules* for more details on this analogy.

As it happens, $D(\mathbb{C}G)$ is a ribbon Hopf algebra. Readers wishing to check this should first find $R = \sum_{h,g \in G} (g^\vee \otimes 1_G) \otimes (h^\vee \otimes g)$, then (recall Proposition 2.18) $u = \sum_{g \in G} g^\vee \otimes g^{-1}$, then $S(u) = u$, and that taking the ribbon element ν to be equal to u works.

⁴The *knot group* $\pi_1(S^3 \setminus K)$ is the fundamental group of the knot’s complement in the three-sphere.

In general, there is a canonical action of $D(H)$ on H , given by

$$(\phi \otimes h) \cdot v := \sum \phi(\text{ad}_h(v)_1) \text{ad}_h(v)_2.$$

When $H = \mathbb{C}G$, this becomes

$$(\phi \otimes h) \cdot a = \phi(hah^{-1})hah^{-1}$$

for all $a \in G$.

Putting it all together:

Proposition 3.17. *Let G be a finite group and K be a knot. In the procedure described at the beginning of Section 3.3, taking $D(\mathbb{C}G)$ as the ribbon Hopf algebra and $\mathbb{C}G$ as the module yields the invariant*

$$\# \text{Hom}(\pi_1(S^3 \setminus K), G).$$

We sketch the proof and encourage readers familiar with the knot group to work out the details. Using $R = \sum_{h,g \in G} (g^\vee \otimes 1_G) \otimes (h^\vee \otimes g) \in D(\mathbb{C}G)$, we compute the braiding maps involving $\mathbb{C}G$ and $\mathbb{C}G^*$. For example, $\Psi_{\mathbb{C}G, \mathbb{C}G}(a \otimes b) = aba^{-1} \otimes a$ for any $a, b \in G$. Figure 10(b) shows this computation in the context of an intermediate morphism $\text{id} \otimes \Psi_{\mathbb{C}G, \mathbb{C}G} \otimes \text{id}$ within a knot diagram. In general, the braiding maps will correspond to “conjugation at each crossing”.

In computing the morphism $\mathbb{C} \rightarrow \mathbb{C}$ represented by the knot diagram, one encounters a large summation where each term acts as an indicator variable for a labeling of the “arcs” of the knot diagram with elements of G . The term evaluates to 1 if and only if the labeling is “compatible” with the conjugations occurring at the crossings. Those familiar with the *Wirtinger presentation* of the knot group will recognize that a compatible labeling is precisely the data needed to determine a group homomorphism $\pi_1(S^3 \setminus K) \rightarrow G$, where each generator of $\pi_1(S^3 \setminus K)$ is sent to the group element labeling its corresponding arc.

A final remark: recall the quantized enveloping Lie algebra $U_q(\mathfrak{g})$ mentioned at the beginning of Section 2. Applying the quantum knot invariant method with $U_q(\mathfrak{sl}_2)$ and its two-dimensional representation yields a knot invariant (parametrized by q). This knot invariant turns out to be a generalized version of the celebrated *Jones polynomial*.

References

- [1] S. Dascalescu, C. Nastasescu, and S. Raianu. *Hopf Algebras: An Introduction*. Marcel Dekker, Inc., New York, NY, 2000.
- [2] C. Kassel, M. Rosso, and V. Turaev. *Quantum Groups and Knot Invariants*. Panoramas et Synthèses. Société Mathématique de France, 1997.
- [3] S. Majid. *A Quantum Groups Primer*. London Mathematical Society Lecture Note Series. Cambridge University Press, Cambridge, UK, 2002.
- [4] V. Turaev and A. Virelizier. *Monoidal Categories and Topological Field Theory*. Progress in Mathematics. Birkhauser, Cham, Switzerland, 2017.